

(RHD) Toyota Land Cruiser GXL Tubro 4.5L V8 Diesel 2020



ENGINE

Name 1VD-FTV
Displacement (cm³) 4461
Max power (kW/rpm) 200/3600
Max torque (Nm/rpm) 650/1600 – 2600
Valve train DOHC
Fuel system Common Rail Direct Injection
Bore x Stroke (mm) 86 x 96
Compression ratio 16.8:1
Fuel economy² (combined) 9.5L/100km

TRANSMISSION

Differential ratio 3.909:1
Transmission type Automatic 6-speed Electronic Control Transmission with Artificial Intelligence Shift Control and Sequential Shift
Transmission ratios 1st 3.333; 2nd 1.960; 3rd 1.353; 4th 1.000; 5th 0.728; 6th 0.588; Reverse 3.061
Transfer ratio high / low 1:1 / 2.618:1
Centre differential Torsen Limited Slip Centre Differential
4x4 drive mechanism Full time

STEERING

Type Power assisted rack and pinion
Turning circle – kerb to kerb (m) 11.8

BRAKES

Front 340mm ventilated discs
Rear 345mm ventilated discs

SUSPENSION

Front Independent double wishbone with a coil spring, gas dampers and anti-roll bar
Rear 4-link coil rear suspension with Panhard rod with coil springs, gas dampers and anti-roll bar



(RHD) Toyota Land Cruiser GXL Tubro 4.5L V8 Diesel 2020

WEIGHTS (APPROXIMATE)

Kerb weight¹ (kg) 2640
Gross Vehicle Mass¹ (GVM)(kg) 3350
Gross Combined Mass¹ (GCM)(kg) 6850
Maximum roof load¹ (kg) 200

SEATING CAPACITY

Seating 8

TOWING CAPACITY

With trailer brakes³ (kg) 3500 Without trailer brakes³ (kg) 750

FUEL TANK CAPACITY

Main (93L) / Sub (45L) 138L Diesel Particulate Filter (DPF)

EXTERIOR

LED headlamps with auto-leveling Front fog lamps

Privacy glass

Side steps

Spare tyre mounted underside of cargo floor

LED rear license plate illumination

WHEELS

Tyre size 285/65R17

Rim type 17" steel

INTERIOR

Premium steering wheel and gear lever

Passenger assist grips and grab handles

Drivers 6-way manual seat adjustment

and power lumbar support

Second row seat: 60/40 split folding seat backs

Third row seat: side folding and 50/50 split seat backs

FEATURES

Smart entry and start system

Dual-zone front climate control air conditioning with rear cooler controls

Power windows with auto up/down (all windows) Accessory power sockets:

front (12V) and rear (220V)

INSTRUMENTS AND CONTROLS

Cruise control

Premium steering wheel with audio,

MID and telephone controls

4.2" Multi Information Display (MID)

MULTIMEDIA

Digital radio⁵

Single disc CD player with 6.1" LCD touchscreen, MP3 compatibility⁴ and

AM/FM tuner

USB input for some iPod⁶/USB⁴ memory sticks Bluetooth⁷ connectivity

Number of speakers 6

Satellite navigation⁵

4WD TECHNOLOGIES

Crawl control (incorporating Off-road Turn Assist)

SAFETY

Reversing camera

Front and rear parking sensors

Vehicle Stability Control (VSC)

Active Traction Control (A-TRC)

Hill-start Assist Control (HAC)

Multi-Terrain Anti-lock Braking System (ABS) Driver

and front passenger SRS frontal, knee, first row side and

first and second row curtain airbags

Third row curtain airbags

Child restraint anchorage points x 3

Luggage tie down hooks

SECURITY

Engine immobiliser

Alarm

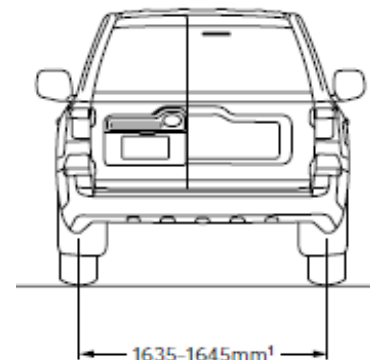
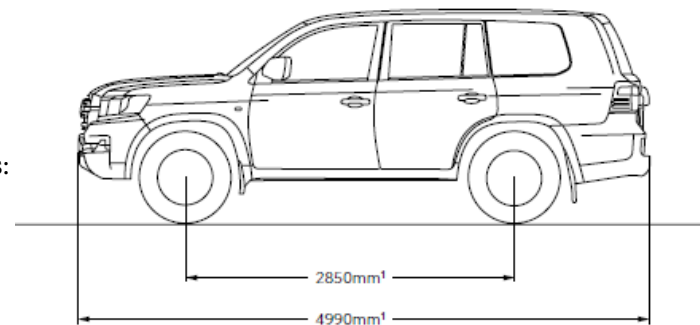
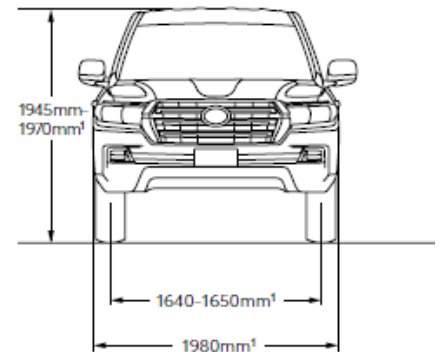



(RHD) Toyota Land Cruiser GXL Tubro 4.5L V8 Diesel 2020





(RHD) Toyota Land Cruiser GXL Tubro 4.5L V8 Diesel 2020

